



# Easy therm

*induction heaters*

**Controllable, fast, clean and save heating system for bearings, couplings and other parts. Stress-free mounting ensured.**



# Easy puller

*bearing pullers*



**Complete program high quality, save and reliable bearing pullers with self centrating jaws. Force from 2 till 100 ton!**



[www.tm-induction.com](http://www.tm-induction.com)

*TM induction heating has manufactured induction heaters for more than 25 years, under the brand name "TM induction heating". Induction heaters for heating up bearings, bushings, gears, pulleys and couplings. Through constant innovation and our extensive experience we are able to offer a technical and reliable product.*

## The Pioneers in the use of induction applications

### Advantages of TM Easy therm induction heaters:

- Fast controllable heating process.
- Safe heating process; only the work piece is heated.
- Elimination of hot oil bath, no risk of localized overheating.
- Suitable for sealed and shielded bearings.
- Suitable for pre-greased bearings.
- Suitable for bearings with polyamide cages.

### Technical advantages of TM Easy therm induction heaters:

- Manufactured according to the **CE** Regulations.
- Fast heating process through high output; **Cos phi > 0,8**.
- **"TURBO-BOOST"**: In the horizontal position the parts will heat up twice as fast.
- The heating coil is placed horizontal under the part;
  - By this it is impossible to damage the coil
  - This ensures an equal temperature all over the part (inner- and outer ring).
  - This makes it able to heat up parts with smaller bores.
- All heaters are **continuously useable** without any optional cooling system.
- Constantly monitoring heating process by probe and microprocessor.
- Temperature control accuracy +/- 2°C.
- Timer accuracy 0,01 sec.
- Maintenance free.
- **Three years** warranty.
- Easy to use; user friendly design.
- Ergonomic design (**pivoting yoke principle**).
- **Automatic power regulation**, no manual pre-setting necessary.
- Less than 2A/cm residual magnetism.

*The pivoting yoke has the great advantage that only the work piece is handled, because the arm does not have to be lifted manually. This avoids unnecessary handling and reduces the risk of dirt intruding into the bearing or work piece.*

Measurements heaters and parts:

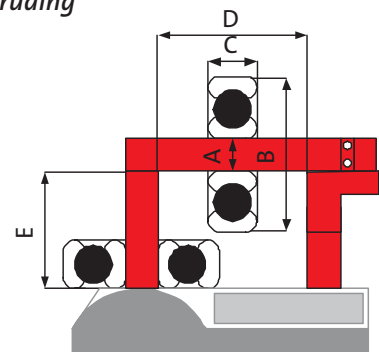

## Easy therm 2

The Easy therm 2 is a small powerful microprocessor controlled induction heater for heating of small sized components including bearings up to 40 kg!! It is easy to use and portable, complete with a robust case, ideal to use on location.



Display



Increase Temperature



Decrease Temperature



### Technical information

Voltage	110-230V
Frequency	50 or 60Hz
Power	3.6kVA
Heater mass	17kg
Dimensions	345x200x240mm
Temp. mode	Max. 240/400°C
Width U-core	120mm
Height U-core	100mm

### Dimensions:

Size induction yokes mm	Standard min. bore part (A)	Standard max. outer diameter part (B)	Standard max. width part (C)	Max. weight part	Max. outside diameter with extension yoke 40x50x75mm	Max. width with extension yoke 40x50x75mm
10x10x200	15mm	210mm	120mm	5kg	360mm	120mm
14x14x200*	20mm	215mm	120mm	15kg	365mm	120mm
25x25x200*	35mm	225mm	120mm	25kg	375mm	120mm
40x40x200*	60mm	280mm	120mm	40kg	375mm	120mm

\*Standard delivered within induction heater.

## Easy therm 3.5

The Easy therm 3.5 is a powerful stationary microprocessor controlled induction heater with an ergonomic pivoting yoke. To be used for the professional mounting of a range of parts including bearings, typically used in maintenance shops and production areas.

### Easy therm 3.5 non pivoting

The Easy therm 3.5 is available without pivoting yoke.

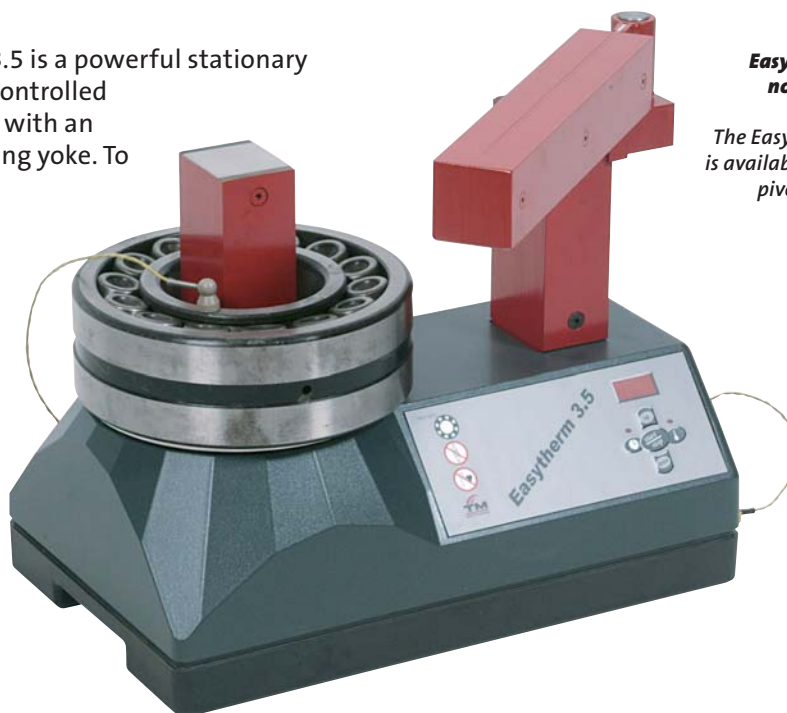
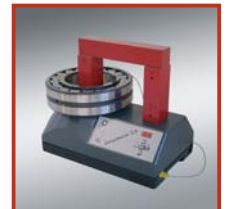

### Technical information

Voltage	110-230V
Frequency	50 or 60Hz
Power	3.6kVA
Heater mass	31kg
Dimensions	420x260x360mm
Temp. mode	Max. 240/400°C
Width U-core	180mm
Height U-core	160mm

### Dimensions:

Size induction yokes mm	Standard min. bore part (A)	Standard max. outer diameter part (B)	Standard max. width part (C)	Max. weight part	Max. outside diameter with extension yoke 50x50x120mm	Max. width with extension yoke 50x50x120mm
10x10x280	15mm	330mm	180mm	5kg	570mm	180mm
14x14x280	20mm	345mm	180mm	15kg	585mm	180mm
25x25x280	35mm	355mm	180mm	25kg	595mm	180mm
40x40x280	60mm	360mm	180mm	40kg	600mm	180mm
50x50x280	70mm	410mm	180mm	35/70kg	600mm	180mm

\*Standard delivered within induction heater.



## Easy therm 15

The Easy therm 15 is a powerful 400 Volt stationary microprocessor controlled induction heater with an ergonomic pivoting yoke, to be used for the professional mounting of a range of parts including bearings, typically used in maintenance shops and production areas.

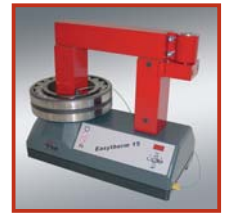

### Technical information

Voltage	380-480V
Frequency	50 or 60Hz
Power	12.8kVA
Heater mass	51kg
Dimensions	505x260x440mm
Temp. mode	Max. 240/400°C
Width U-core	210mm
Height U-core	215mm

### Dimensions:

Size induction yokes mm	Standard min. bore part (A)	Standard max. outer diameter part (B)	Standard max. width part (C)	Max. weight part	Max. outside diameter with extension yoke 70x70x150mm	Max. width with extension yoke 70x70x150mm
20x20x350	30mm	460mm	210mm	15kg	760mm	210mm
30x30x350	45mm	475mm	210mm	20kg	775mm	210mm
40x40x350	55mm	485mm	210mm	25kg	785mm	210mm
50x50x350	70mm	500mm	210mm	35kg	800mm	210mm
60x60x350	85mm	515mm	210mm	60kg	815mm	210mm
70x70x350	100mm	515mm	210mm	150kg	815mm	210mm

**Easy to use; the process is entirely microprocessor controlled. The operator only needs to set the temperature or time, other features like power reduction will be automatically recognized.**

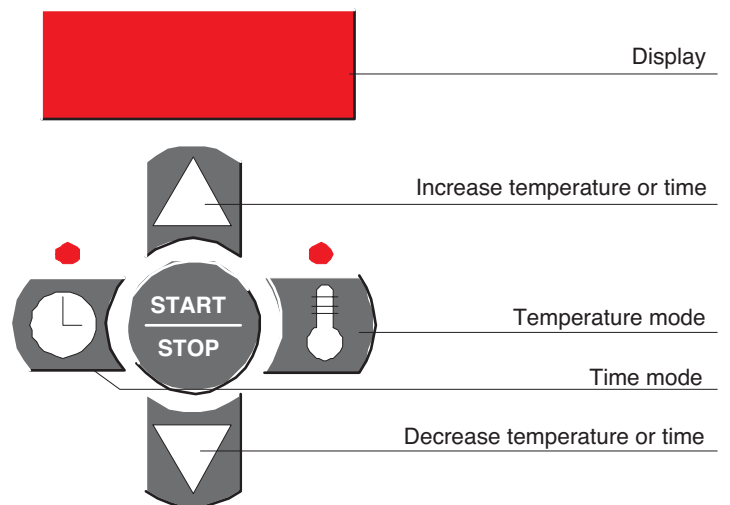

## Easy therm 30

The Easy therm 30 is a powerful 400 Volt stationary microprocessor controlled induction heater with an ergonomic pivoting yoke, to be used for the professional mounting of a range of parts including bearings, typically used in maintenance shops and production areas.

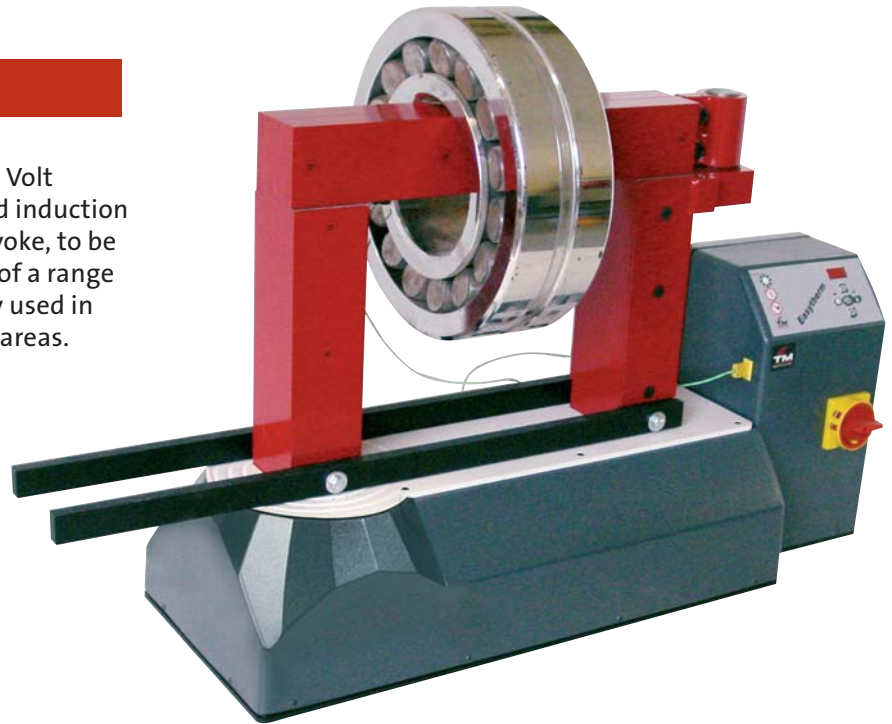

### Technical information

Voltage	380-480V
Frequency	50 or 60Hz
Power	12.8kVA
Heater mass	60kg
Dimensions	880x320x570mm
Temp. mode	Max. 240/400°C
Width U-core	330mm
Height U-core	295mm

### Dimensions:

Size induction yokes mm	Standard min. bore part (A)	Standard max. outer diameter part (B)	Standard max. width part (C)	Max. weight part	Max. outside diameter with extension yoke 80x80x150mm	Max. width with extension yoke 80x80x150mm
20x20x490	30mm	620mm	330mm	15kg	910mm	330mm
30x30x490	45mm	630mm	330mm	20kg	920mm	330mm
40x40x490	55mm	640mm	330mm	25kg	930mm	330mm
50x50x490	70mm	650mm	330mm	35kg	940mm	330mm
60x60x490	85mm	660mm	330mm	60kg	950mm	330mm
70x70x490	100mm	670mm	330mm	80kg	960mm	330mm
80x80x490	115mm	740mm	330mm	300kg	960mm	330mm

## Easy therm 30 with trolley

With the trolley the Easy therm 30 can easily be assembled into a movable model. The large castors make it easily movable and allow the unit to be used where needed.

### Technical information

Voltage	380-480V
Frequency	50 or 60Hz
Power	12.8kVA
Heater mass	85kg
Dimensions	1060x500x1090mm
Temp. mode	Max. 240/400°C
Width U-core	330mm
Height U-core	295mm



## Easy therm 60

The Easy therm 60 is a robust powerful 400 Volt stationary microprocessor controlled induction heater, to be used for the professional mounting of heavy parts including bearings, typically used in maintenance shops and production areas.

With easy to fit lift installation and rail system for the parts, the Easy therm 60 can be assembled to an ergonomic production machine. (see optional parts)

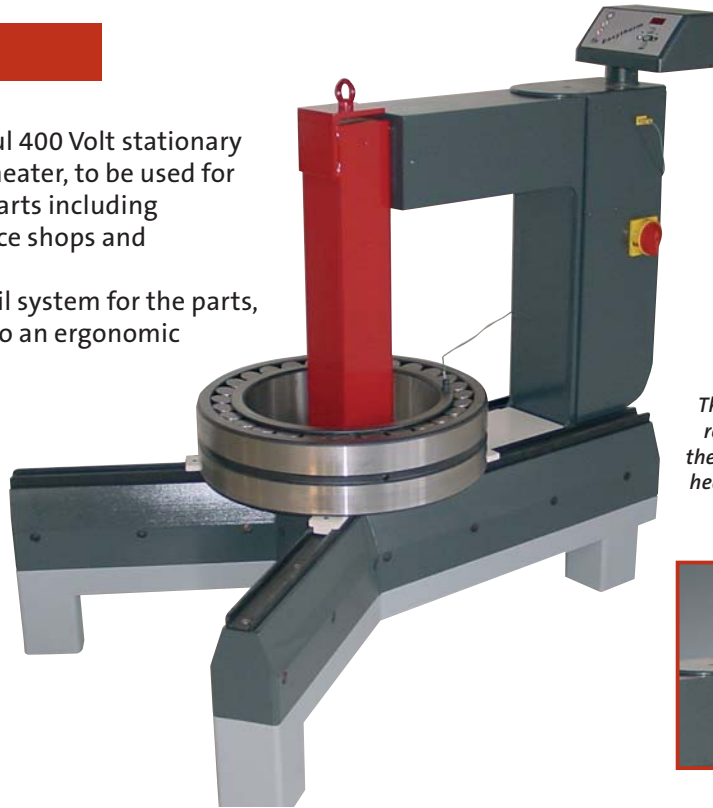

The operating panel rotates, this allows the user to follow the heating process from every angle



### Dimensions:

Size induction yokes mm	Standard min. bore part (A)	Standard max. outer diameter part (B)	Standard max. width part (C)	Max. weight part
40x40x700	55mm	840mm	410mm	700kg
60x60x700	85mm	860mm	410mm	700kg
80x80x700	115mm	880mm	410mm	700kg
100x100x700	145mm	900mm	410mm	700kg

### Technical information

Voltage	380-480V
Frequency	50 or 60Hz
Power	25kVA
Heater mass	350kg
Dimensions	780x1200x1060mm
Temp. mode	Max. 240/400°C
Width U-core	440mm*
Height U-core	390mm*

Other measurements on request

## Easy therm 100



The operating panel rotates, this allows the user to follow the heating process from every angle



The Easy therm 100 is a robust powerful 400 Volt stationary microprocessor controlled induction heater, to be used for the professional mounting of heavy parts including bearings, typically used in maintenance shops and production areas, for instance paper-mills and steel-mills. With easy to fit lift installation and rail system for the parts, the Easy therm 100 can be assembled to an ergonomic production machine. (see optional parts)



### Technical information

Voltage	380-480V
Frequency	50 or 60Hz
Power	40kVA
Heater mass	800kg
Dimensions	1200x1700x1250mm
Temp. mode	Max. 240/400°C
Width U-core	470mm*
Height U-core	690mm*

Other measurements on request

### Dimensions:

Size induction yokes mm	Standard min. bore part (A)	Standard max. outer diameter part (B)	Standard max. width part (C)	Max. weight part
60x60x850	85mm	1500mm	470mm	1250kg
80x80x850	115mm	1500mm	470mm	1250kg
100x100x850	145mm	1500mm	470mm	1250kg
150x150x850	215mm	1500mm	470mm	1250kg



## Easy therm 250

The Easy therm 250 is a very robust and powerful 400 Volt stationary microprocessor controlled induction heater, to be used for the professional mounting of a range of heavy parts including bearings up to 3000 kg, typically used in maintenance shops and production areas, for instance gearbox manufacturers.

*The Easy therm 250 is a custom made product, Parts up to 10.000 kg can be heated up with a modification of the coil*



**When press mounting is not an option the Easy therm 250 offers the solution.**

### Dimensions:

Size induction yokes mm	Standard min. bore part (A)	Standard max. outer diameter part (B)	Standard max. width part (C)	Max. weight part
150x150x1250	215mm	2000mm	620mm	3000kg
200x200x1250	284mm	2000mm	620mm	3000kg

### Technical information

Voltage	380-480V
Frequency	50 or 60Hz
Power	100kVA
Heater mass	1800kg
Dimensions	1500x3000x2000mm
Temp. mode	Max. 240/400°C
Width U-core	750mm*
Height U-core	1000mm*

*Other measurements on request*

## Easy therm 250 special

The Easy therm 250 Special is developed for the windmill industry. This heater is able to heat up parts with a weight of 10.000 kg with an outside diameter of 4000mm in 60 minutes up to 120°C.



*The sliding yoke makes it ergonomic to use, there is no crane necessary to remove the heavy induction yoke*



### Technical information

Voltage	380-480V
Frequency	50 or 60Hz
Power	100kVA
Heater mass	1800kg
Dimensions	1000x3000x2000mm
Temp. mode	Max. 240/400°C
Width U-core	1200mm*
Height U-core	1000mm*

*Other measurements on request*

## Optional parts and spare parts

### Extension yokes

With extension yokes the user is able to heat up bigger parts on a standard Easy therm induction heater.

#### Dimensions:

Type heater	Measurements set of extension yokes	Max. outside diameter part
Easy therm 2	50x50x75	375mm
Easy therm 3.5	50x50x120	600mm
Easy therm 15	70x70x150	770mm
Easy therm 15	70x70x200	870mm
Easy therm 30	80x80x150	980mm
Easy therm 30	80x80x200	1080mm

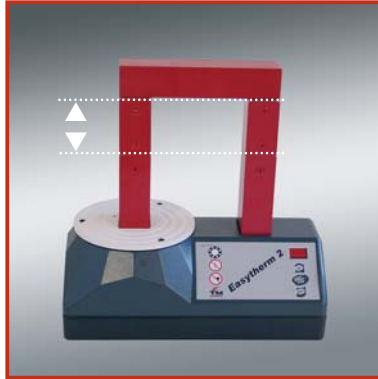

Max O.D. with a set extension yokes

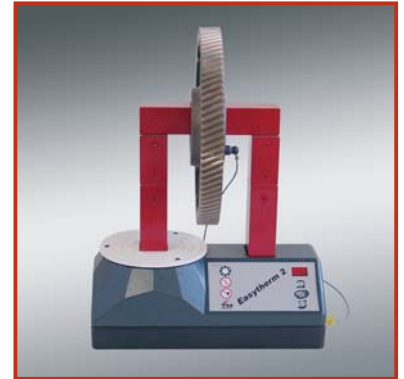

### Lifting device for Easy therm 60 and 100

The easy to assemble lifting device makes it possible to lift the heavy induction yoke. With this device an external elevating crane is not needed.



### Sliding table system for Easy therm 60 and 100

The easy to assemble sliding table makes it easier to handle the heavy part.





## Fitting tool set



For a safe, precise and quick mechanical mounting of bearings, bushings, sealing rings and pulleys. This set is usable for fitting more than 230 sizes of bearings with a bore from 10 to 50mm. The set consist of three special aluminium impact sleeves, 33 synthetic impact-resistant collets and a dead blow hammer, delivered in a robust plastic case.

The relief on the tubes realizes a perfect grip.

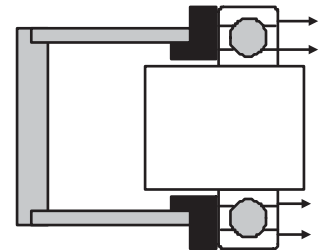
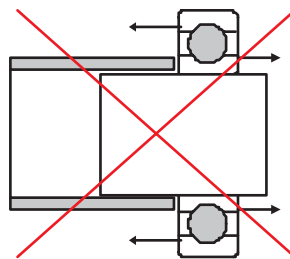
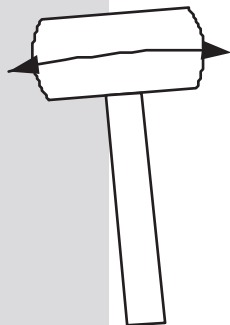

For bearings it is important that during mechanical mounting the bearing is supported on its inner- and outer ring to avoid unnecessary damage. In this way mounting forces are not transmitted via balls or rollers of the bearing. Through the use of impact resistant synthetic collets metal to metal contact is avoided.

## Easy puller 50

### Mobile, hydraulic 50 ton puller

to dismantle bearings, couplings and other large sized parts.

- Efficient; one man can do the job.
- Ergonomic: No manual adjustment necessary.
- Manufactured according to the latest CE regulations.
- Big reach: from 65 to 1150mm!
- 50 ton Hydraulic double-acting cylinder.
- Hydraulically vertical lift system.
- Hydraulically-actuated self-centring jaws, by one push on the button the puller jaws will automatically grip behind the part.
- Only one remote control for the different handlings.
- Puller can be assembled in 2- or 3 jaw configuration.
- Safety; the puller is delivered with a special safety blanket and safety instructions.
- The lifting brackets allows the puller to be lifted in a crane.
- Robust castors makes it easily movable.

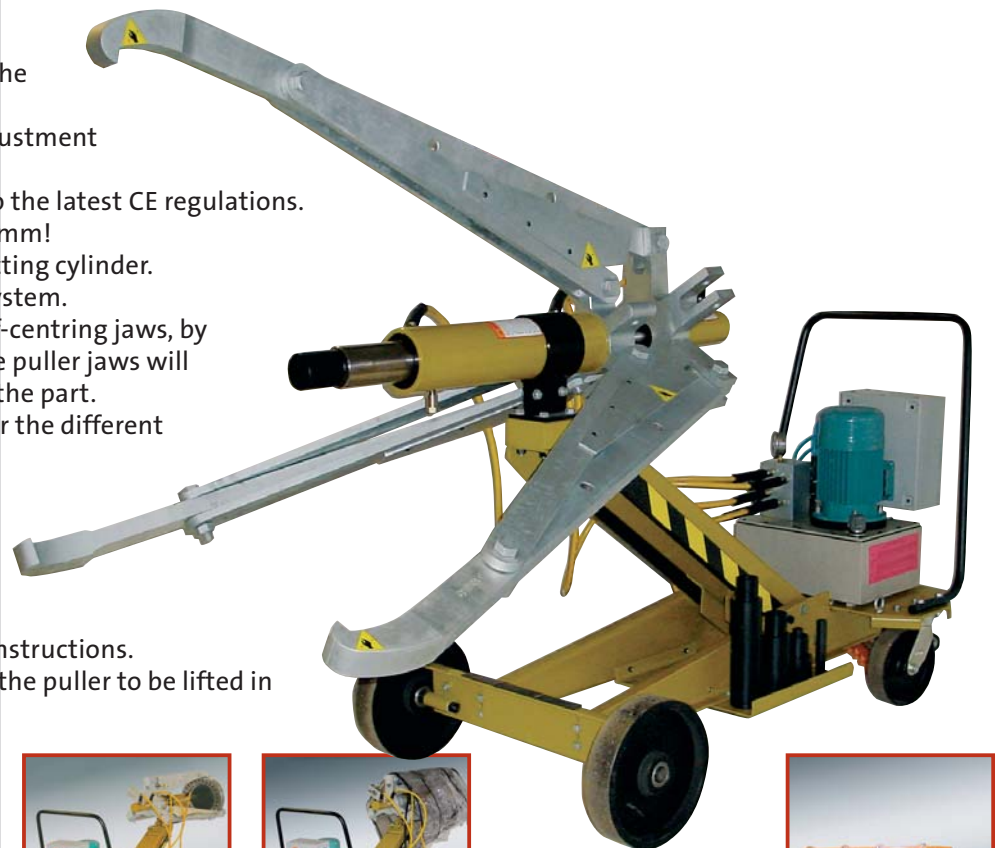

*The safety blanket assures a safe dismantling procedure*

#### Remote control with 8 mtr cable for 6 different functions

- Vertical adjustment
- Adjustment of self-centring arm
- Operate 50 tons double acting cylinder

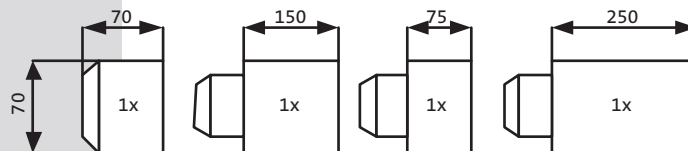

The Easy puller 50 is delivered with 4 different kind of Pushing adapters

#### Dimensions:

Maximum spread	reach at minimum Spread	Maximum spread	Reach at maximum spread	vertical height adjustment	Cylinder stroke	Weight puller	Measurements puller
64mm	651mm	1150mm	559mm	450 to 1120mm	337mm	481kg	3015x963x1276mm

Power hydraulic pump 230V, other voltages on request



## Easy puller 100

### Mobile, hydraulic 100 ton puller

to dismantle bearings, couplings and other large sized parts.

- Efficient; one man can do the job.
- Robust and compact construction.
- Manufactured according to the latest CE regulations.
- Big reach: from 380 to 1219mm!
- 100 ton Hydraulic double-acting cylinder.
- Vertical adjustable, manual or electrical (optional).
- High quality jaws are adjustable this means they always pull on a flat surface.
- Remote control with 8 mtr cable.
- Safety; the puller is delivered with a special safety blanket and safety instructions.
- The lifting brackets allows the puller to be lifted in a crane.
- Robust castors makes it easily movable.

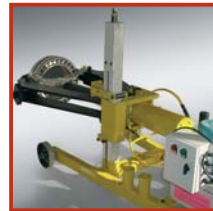
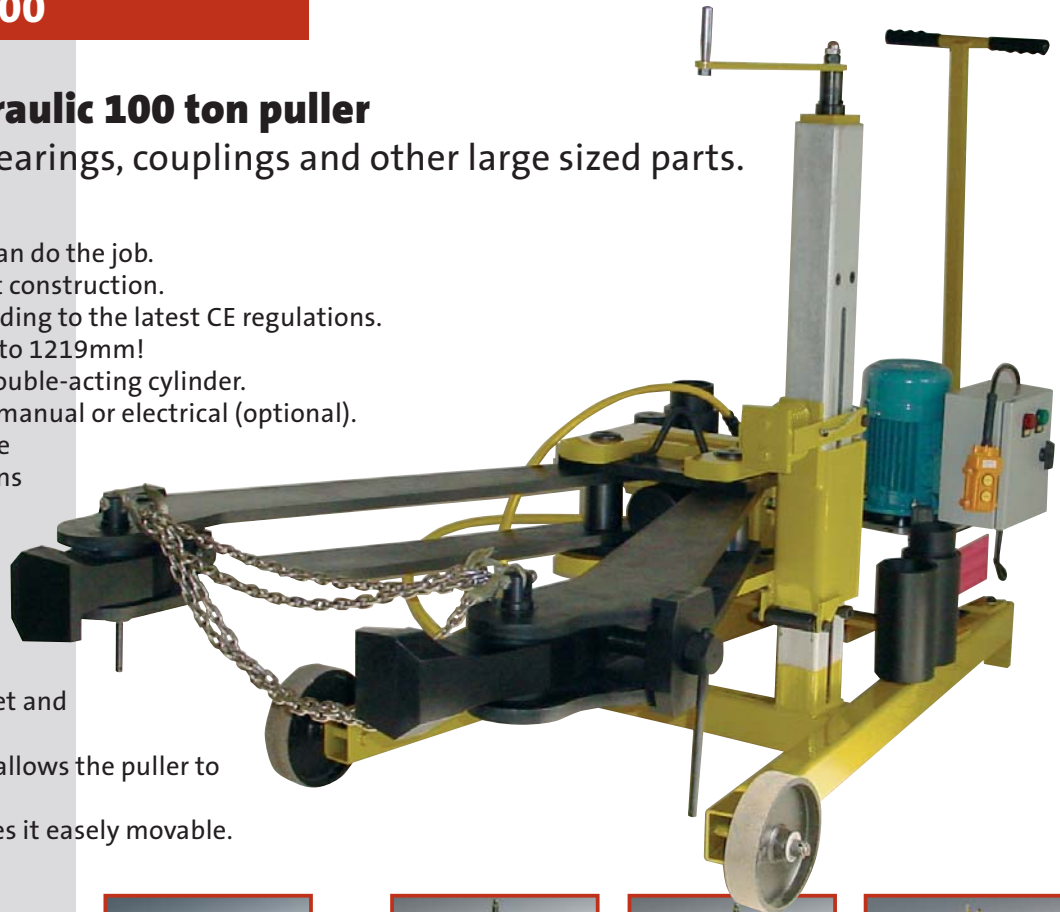

**Remote control with 8 mtr cable**

*The safety blanket assures a safe dismantling procedure.*

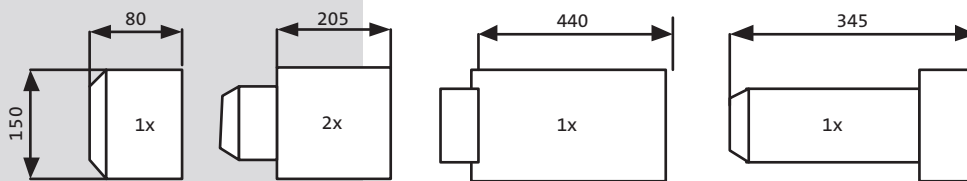

The Easy puller 100 is delivered with 5 different kind of Pushing adapters.

#### Dimensions:

Maximum spread	reach at minimum Spread	Maximum spread	Reach at maximum spread	vertical height adjustment	Cylinder stroke	Weight puller	Measurements puller
380mm	1066mm	1219mm	863mm	305 to 915mm	250mm	433kg	3015x963x1276mm

Power hydraulic pump 230V, other voltages on request

